



PROTOTYPE DESIGN OF FIELD POWER WITH ARDUINO BASED CONTROL

Joni Eka Chandra*¹

¹ Informatics Engineering Study Program, Batam Putera University, Batam

e-mail: *ekacandra@gmail.com,

Abstract

Indonesia is a country that has large rice fields, the lands are plowed manually or traditionally, manually plowing the fields by plowing the fields by pushing the plow around the land and the traditional way plowing the fields using cows. In the current era of technology, a field plow is needed that can be controlled remotely. The author's goal is to design this tool in order to facilitate the work of farmers and change the system of plowing fields from manual to modern. There are two important parts of the design of this tool, namely the design of hardware in the form of a prototype plow tool and software design in the form of a control program. The design for controlling the field plow consists of several components, including: android application as a control tool, bluetooth HC-05 as a communication medium to Arduino Nano, Arduino Nano as a microcontroller that gives commands to Driver L298N to drive a DC motor. This test was carried out 3 times by activating and then disabling the Power Supply. The results obtained from this test are 100% successful without any error/damage.

Keywords— *Android, Bluetooth HC-05, Arduino Nano, Driver L298N, Motor DC*

INTRODUCTION

Indonesia is a large country that has extensive paddy fields, the lands are plowed manually or traditionally, manually plowing the fields, namely plowing the fields by pushing the plow around the land and the traditional way is to plow the fields using cows / buffalo. This is due to the lack of Arduino-Based Control, the availability of modern plows and the lack of knowledge about modern plows. The development of technology in the world today can be said to be very rapid, many academics, companies and the general public are developing and even creating automated tools or remote controls to simplify human work and reduce risks that can occur if done manually.

One of the technologies that has been created is remote control that uses bluetooth as a liaison for remote control. One example is "Home Control Design using an Android Smartphone with bluetooth connectivity". Bluetooth is very often used for designing tools that are made with controls that don't use cables, usually bluetooth is used in several wireless control devices such as Playstation sticks, Smartphones (Android / IOS), remote controls, TV remotes and others.

In the current technological era, the agricultural sector requires a field plow that can be controlled remotely. By utilizing Bluetooth or wireless, it is hoped that a modern plow can be created that can be used by farmers. Based on the problems above, the researchers will make a device that can be controlled remotely. This is the background of the researcher to take the title: "PROTOTYPE DESIGN OF FIELD POWER WITH ARDUINO-BASED CONTROL". By changing the rice field plowing system from manual to modern in the form of a rice field plow controlled using Android via

bluetooth HC-05 based on Arduino, it is hoped that it can ease the work of farmers in plowing the fields.

RESEARCH METHODS

Arduino Nano

Arduino Nano is a board that has Atmega328 or Atmega168. With its small size, this board is very practical to use, making it the most popular microcontroller. This board lacks that it does not have a prot for DC power. And it works only with Mini-B USB cable. The Arduino Nano board is designed and manufactured by Fravitech (Sadewo, Widasari, & Muttaqin, 2017).



Picture 1. Arduino Nano

Table 1. Arduino Nano Specifications

No	Mikrokontroler	Atmega168 atau Atmega328
1	Tegangan Operasi	5 V
2	Tegangan <i>Input</i>	7-12V
3	Batas Tegangan <i>Input</i>	6-20V
4	Pin I/O Digital	14 (dimana 6 dipakai untuk <i>output</i> PWM)
5	<i>Pin Input Analog</i>	8
6	Arus DC per pin I/O	40 mA
7	Flash Memory	16 KB (untuk Atmega 168) atau 32 KB (untuk Atmega328)
8	SRAM	1 KB (untuk Atmega 168) atau 1 KB (untuk Atmega328)
9	EEPROM	512 Bytes (untuk Atmega168) atau 1 KB (untuk Atmega 328)
10	Kecepatan Clock	16 MHz
11	Dimensi	0,73 cm x 1,70 cm
12	Panjang	45 mm
13	Lebar	18 mm
14	Berat	5 g

Bluetooth Module HC-05

The HC-05 Bluetooth module is a module that can be two slave or master modes with a communication frequency of 2.4 GHZ. This module has an effective range of 10 meters. This module is also easy to use to build a wireless system (Sadewo et al., 2017). The HC-05 module runs on 3.0 low power operation and 3.0 to 4.2 V I/O control. It has an integrated antenna, edge connector and UART interface with programmable baud rates. The HC-05 module has default

baud rate: 38400, data bit 8, stop bit: 1, parity: no parity and supported baud rates are 9600, 19200, 38400, 57600, 115200, 230200, 23400, 460800 (Jayantilal, 2014).



Figure 2. Bluetooth Module HC-05 Motor Driver Module L298N

Motor Driver functions as a regulator of the direction of rotation of the motor and the speed of rotation of the motor. The motor driver is needed for the Arduino board because Arduino is only able to issue a small current so it is not able to meet the needs of a DC motor, so it needs a motor driver to adjust the voltage and current needed by the motor. L298N is a driver for DC motors as well as stepper motors. One L298N IC is capable of operating at a voltage of 2.5 V to 46 V. The L298N IC can provide a current of up to 2 amperes. But in the use of this IC can be used in parallel, so it is able to provide a current to 4 A and has protection against excessive temperature. Active pins A and B to control the motor running speed, or insert pins 1 to 4 to control the direction of rotation. Activate pin by giving VCC 5 V for full speed.



Figure 3. L298N DC Motor Driver Module



Figure 4. Li-Ion (Lithium-Ion) Battery DC Motor

A DC motor is a motor that rotates 360 degrees, usually called a dynamo and usually used as a drive wheel. If the positive and negative poles of the installed source are exchanged, the DC motor will rotate in the opposite direction from the previous rotation direction. A direct current motor (DC motor) is a machine that converts direct current electrical energy into mechanical energy. An electric motor functions to convert electrical power into mechanical power. On the principle of operation, direct current motors are very similar to direct current generators. In fact a machine that works as a direct current generator will be able to work as a direct current motor. Therefore, a direct current machine can be used as either a direct current motor or a current generator. In this battery, lithium ions move from the negative electrode to the positive electrode when discharged, and back when recharged. Li-ion batteries use an intercalated lithium compound as their electrode material, in contrast to the metallic lithium used in non-rechargeable lithium batteries. Lithium ion batteries are commonly found in consumer electronics. This battery is the most popular type of rechargeable battery for portable electronic equipment, because it has one of the best energy densities, has no memory effect, and experiences slow charge loss when not in use.



Figure 5. Li-Ion Battery (Lithium-Ion Arduino IDE)

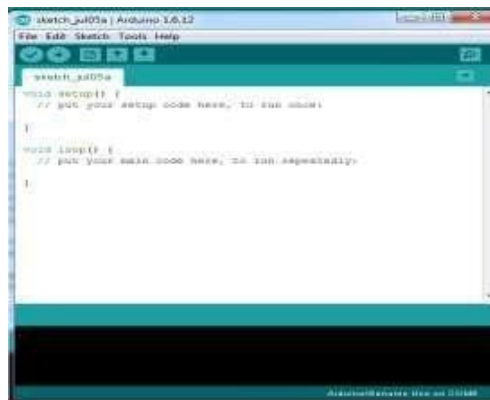

Figure 6. Arduino IDE

Arduino IDE software is an open-source single-board micro controller, derived from the wiring platform, designed to facilitate the use of electronics in various fields of hardware. It has a simple C++ programming language and complete functions, so Arduino is easy to learn by beginners.

frizzing

Frizzing is a free software and is an open source application founded by an online community. Frizzing (Version 0.9 and above) can be used to design double-sided PCBs and can be sent to PCB manufacturers for mass production. Frizzing can also be used for documentation and checking the circuit design that we make. Frizzing is quite easy to use and practical, because it is

widely used by the development of Arduino microcontroller modules, Raspberry-Pi single boards and the like.

Google SketchUp 8

Google SketchUp is software that can be used to model 2D and 3D objects that are widely used because of the many diversity of features offered and easy to operate. Google SketchUp can be used in various fields, including education as a learning tool, architectural design, to the layout of a country's city.



Figure 7. Fritzing

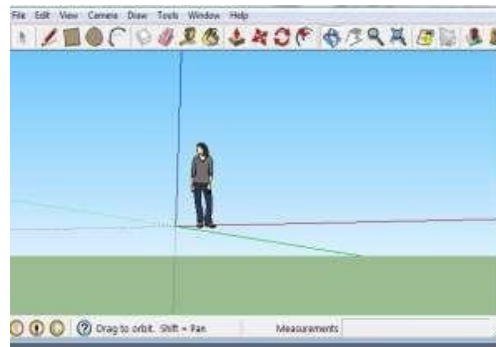

Figure 8. Google SketchUp 8

Arduino Bluetooth RC Car This application is an application provided by the Android operating system that can be downloaded at the PLAY STORE. The Arduino Bluetooth RC Car application can be used on Android phones that have a bluetooth device which will later be connected to the device to be controlled using a bluetooth device as well. This application provides several control buttons such as forward, backward, left, right, even a car speed control button and other functions are provided.



Figure 9. Arduino Bluetooth RC Car

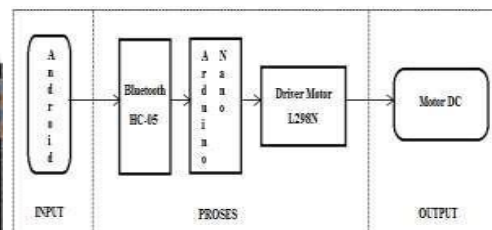

Figure 10. Thinking Framework

RESULTS AND DISCUSSION

Tool Design There are two important parts of tool design, namely hardware design and software design. Hardware Design (Hardware) Hardware design is the most important part in the manufacture of tools / products. This section discusses mechanical and electrical design. Hardware design as the planning stages in tool planning which has the aim of avoiding mistakes that occur when making tools. In planning Arduino Based Control The construction of the tool requires the help of Google SketchUp software which can design three-dimensional images. For electrical design, it requires the help of frizzling software and Microsoft Word to design electronic circuits.

1. Mechanical Design The tool made is a prototype of a field plow designed using a toy frame, iron plate and iron curtains as a dredger / to loosen the soil. The overall design of the tool is shaped like a tractor in general.

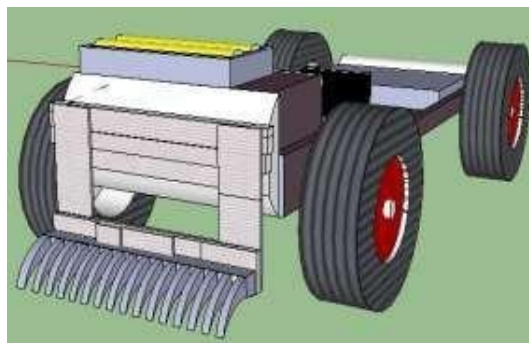

Figure 11. Rice Plow Tool Design

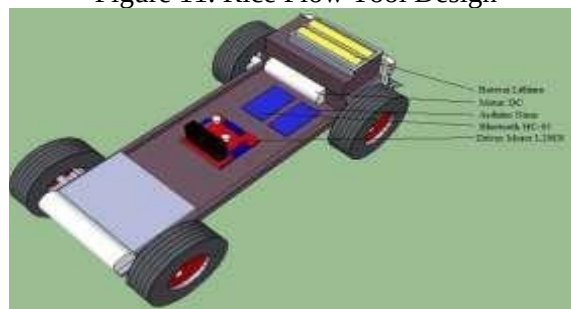

Figure 12. Mechanical Components of the Rice Plow Equipment System

2. Electrical Design The control of this field plow uses Android to drive a DC motor, the components that need to be assembled include: Arduino Nano which is connected to bluetooth HC05 and L298N driver as a communication medium to drive a DC motor which functions to drive the prototype of the field plow.

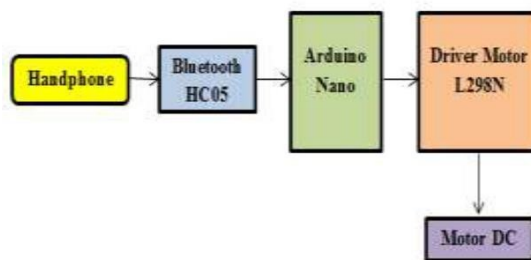

Figure 13. Block Diagram of Rice Plow Tool Control

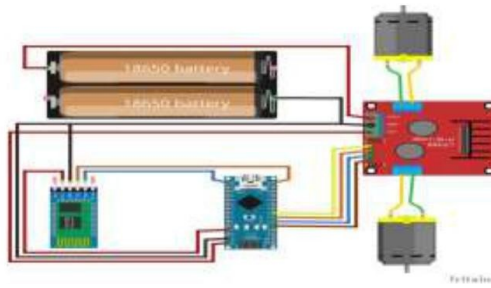

Figure 14. Wireless Control Electronic Hardware System Design

Block diagrams are one of the most important parts in making this tool. Block diagrams are used to simplify the process of designing each circuit so as to form a system.

Software Design (Software)

Software design shows how the working system of the tools made. The program flow in this study is to start the program by providing a voltage source for all circuits. Furthermore, the Arduino system can receive signals from android phones that are connected using bluetooth HC05 to run a DC motor using the L298N motor driver. A flow chart to describe the working system of the tool that is made can be seen in the following figure:

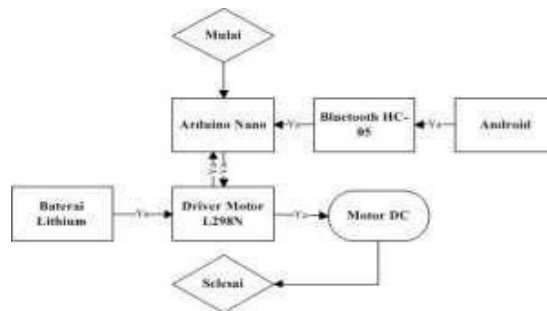

Figure 15. Program Flowchart

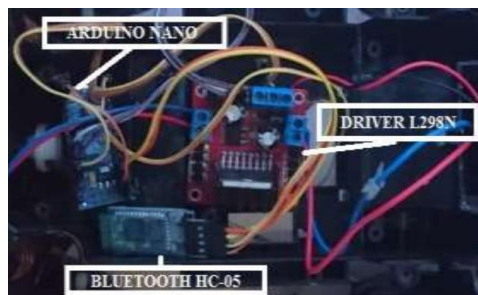

Figure 16. Plow Control System Block

Table 2. Control Blocks and Circuit Functions

Nama Bagian	Fungsi
Bluetooth HC-05	Sebagai media komunikasi data antara android dengan board Arduino
Arduino Nano	Sebagai Sistem Kontrol Alat Bajak Sawah
Driver Motor L298N	Untuk Mengatur putaran motor DC

Mechanical Design Results a. The tire diameter is 16 cm, consisting of: 10 cm rim width and 6 cm tire thickness. b. The height of the plow is 13 cm. c. The length of the plow is 43 cm. d. Width of the plow 22 cm e. Distance between front and rear tires 23 cm f. The width of the soil scraper is 20 cm. g. The length of the soil scraper is 7 cm.



Figure 17. Mechanical Design of a Plow Plow Figure 18. Android Application

Test result

The test results are one of the important steps that must be taken because it is to find out whether the tool made is in accordance with what has been planned or not. Testing of Control Devices Using Wireless The testing of wireless control carried out is divided into 2 parts, namely: testing the buttons on the software and testing the distance range of the wireless controller.

1. Testing the buttons on the android software

Testing The buttons on the Android software are tested in stages, namely by pressing one by one the control buttons used in the Arduino-Based Control software alternately. The test results can be seen through the Arduino IDE Software serial monitor. The following are the results of testing the control buttons on the Android software with large functions on the electrical system.

Table 4. Testing the buttons on the Android software

Bagian Tombol software Android yang digunakan	Serial Monitor Arduino IDE	Ket
Button	2	Maju
Button	3	Mundur
Button	4	Kanan
Button	5	Kiri

2. Wireless Controller Range Testing Testing the distance of the control device using wireless by controlling the mechanics of the field plow gradually starting from 1 meter per distance until the data communication signal range of the control system is cut off. or by viewing the data communication via the Arduino IDE Serial Monitor Software.

Table 5. Testing Results of Control Device Distance Using Wireless

Pengujian	Jarak
Terhalangan	0-11 Meter
Tanpa Halangan	0-15 Meter

Power Supply Test Power Supply testing can be done by measuring the use of voltage and electric current for each electrical component by using an electrical measuring instrument, namely a multimeter. Testing the Power Supply on this tool consists of 2 parts, namely 12 VDC for the motor voltage and 5 VDC for the HC-05 Bluetooth module, Arduino Nano. The following is the Power Supply test carried out:

Table 6. Power Supply Test Results for electronic components

Nama Bagian	Pin IN/OUT	Tegangan	Arus	
Arduino Nano	VIN	5VDC	-	
	D2	5VDC	36mA	
	D3	5VDC	36mA	
	D4	5VDC	36mA	
	D5	5VDC	36mA	
Bluetooth HC-05	VCC	5VDC	30mA	
Driver Motor L298N	VCC	5VDC	5mA	
	IN1	5VDC	-	
	IN2	5VDC	-	
	IN3	5VDC	-	
	IN4	5VDC	-	
VCC IN			12VDC	-
Total Penggunaan Kapasitas <i>Power Supply</i>			179mA	

Table 7. Mechanical Power Supply Test

Posisi Motor DC	Speed	Tegangan	Arus
Depan	11,4VDC		600mA
Belakang	1	3,7VDC	510mA
	2	4,5VDC	520mA
	3	5,3VDC	529mA
	4	6,1VDC	543mA
	5	7,9VDC	555mA
	6	8,7VDC	567mA
	7	9,6VDC	579mA
	8	10,7VDC	588mA
	9	11,4VDC	610mA

Tool Test Results

The results of testing the prototype of the paddy plow with control using Bluetooth based on Arduino were tested 3 times with the same testing steps. The first step is to provide power supply to the prototype components. Then synchronize the Android application with the Bluetooth prototype of the field plow. The final step is testing the prototype of the field plow by controlling it using an application. If the overall test goes according to plan, the final step is to disconnect the power supply that is connected to the electrical components of the prototype plow. This test step was carried out 3 times, the function was to find out whether the prototype control system of the field plow using bluetooth was running according to plan without any errors. The following are the results of the tool testing that has been carried out in accordance with the steps taken.

Table 8. Tool Test Results

Pengujian	Bagian Pengontrolan	Uji Fungsi Button	Hasil Pengujian
1	Motor DC Belakang	Maju dan Mundur	Berhasil 100%
		Kontrol Speed	Berhasil 100%
2	Motor DC Depan	Kanan dan Kiri	Berhasil 100%

CONCLUSION

Based on the results of the discussion and testing of controlling the plow using wireless, the conclusions can be drawn, namely: The design of controlling the plow tool consists of several components, including: android application as a control tool, bluetooth HC-05 as a communication medium to Arduino Nano, Arduino Nano as a microcontroller that gives commands to the L298N Driver to drive a DC motor.

SUGGESTION

The following are suggestions for developing a field plow controlled using Bluetooth HC 05 to achieve better results, including:

1. It is hoped that this plow control system can be implemented not only for the field plow but can be implemented on other tools.
2. This system can only be used to plow rice fields and it is hoped that for further research it can plant rice seeds which are controlled using bluetooth HC-05.
3. The use of the Android operating system as a control medium can be developed using the IOS operating system so that any cellphone can be used.

REFERENCES

- Setiawan, S. I. A. (2011). Google Sketchup Perangkat Alternatif Dalam Pemodelan 3D. *Jurnal ULTIMATICS*, 3(2), 6–10. <https://doi.org/10.31937/Ti.V3i2.298>
- Jayantilal, S. H. (2014). *Interfacing Of AT Command Based HC-05 Serial Bluetooth Modul With Minicom In Linux*. 2(03), 329–332.
- Daud, M., Handika, V., & Bintoro, A. (2018). Design And Realization Of Fuzzy Logic Control For Ebb And Flow Hydroponic System. *International Journal Of Scientific And Technology Research*, 7(9), 138–144.
- Thowil Afif, M., & Ayu Putri Pratiwi, I. (2015). Analisis Perbandingan Baterai Lithium-Ion, Lithium-Polymer, Lead Acid Dan Nickel-Metal Hydride Pada Penggunaan Mobil Listrik -Review. *Jurnal Rekayasa Mesin*, 6(2), 95–99. <https://doi.org/10.21776/Ub.Jrm.2015.006.02.1>
- Rosalina, Qosim, I., & Mujirudin, M. (2017). Analisis Pengaturan Kecepatan Motor DC Menggunakan Kontrol PID (Proportional Integral Derivative). *Seminar Nasional TEKNOKA*, 2(2502–8782), 89–94.
- Sadewo, A. D. B., Widasari, E. R., & Muttaqin, A. (2017). Perancangan Pengendali Rumah Menggunakan Smartphone Android Dengan Konektivitas Bluetooth. *Jurnal Pengembangan Teknologi Informasi Dan Ilmu Komputer*, 1(5), 415–425.

Rio Bagus, R., Elektro, S. T., Teknik, F., Surabaya, U. N., Elektro, D. T., Teknik, F., &

Surabaya,

U. N. (2018). *PENGEMBANGAN TWO WHEELS SELF BALANCING ROBOT DENGAN PI CONTROLLER BERBASIS LABVIEW 2014* Bagus Rio Rynaldo Endryansyah Pada *Two Wheels Self Balancing Robot Berbasis Arduino*. 127–136.

Veza, O. (2016). Simulasi Pengendalian Persediaan Gas Menggunakan Metode Monte Carlo Dan Pola Lcm (Studi Kasus Di PT PKM Group Cabang Batam). *Jurnal Teknik Ibnu Sina JT- IBSI*, 1(01).

Setyabudhi, A. L., & Sirait, G. (2019). Pengembangan Produk Sumber Tenaga Listrik Mini Dengan Pendekatan VDI (Verein Deutscher Ingeniure) 2221.